



RoOil

INSTALLATION/OPERATING AND MAINTANANCE INSTRUCTION

Type of oil separator: _____

Customer of oil separator: _____

Place of instalation: _____





CONTENT

1.	SEPARATOR DESCRIPTION	3
2.	USE OF OIL SEPARATOR	5
3.	COMPONENTS OF OIL SEPARATOR	5
4.	MAINTENANCE	8
5.	TRANSPORT AND INSTALLATION OF OIL SEPARATOR	12
5.1.	SIMPLE UNDERGROUND INSTALLATION.....	14
5.2.	UNDERGROUND INSTALLATION WITH GROUND WATER	15
5.3.	INSTALLATION BELOW TRAFFIC SURFACES	16
5.4.	INSTALLATION DEEP BELOW THE GROUND.....	17
6.	ATTACHMENTS	19
6.1.	MAINTENANCE	19
6.2.	OPERATING LOGS	20
6.3.	OPERATING DIARY	22
6.4.	RULES OF PROCEDURE	24

1. SEPARATOR DESCRIPTION

OPERATION OF OIL SEPARATORS

RoOil separator operates according to the principle of separation water and oil by exploiting a lower specific gravity (density) of the oil against water. Contaminated water with grease and other sludge flows into the settling or first chamber (1) of oil separator. The inlet pipe (2) takes care of the calming of the flow and the almost no turbulent conditions which are required for effective sedimentation. The settler or first chamber (1) has the function of a sludge trap, sand, fine sludge and other rough dirt and keeps them on the bottom of the first chamber, so the coalescent oil filter (3) is relieved to the maximum extent. It follows sedimentation of rough dirt and fine mud, as well as raising oil drops and other fats to the surface of the water level.

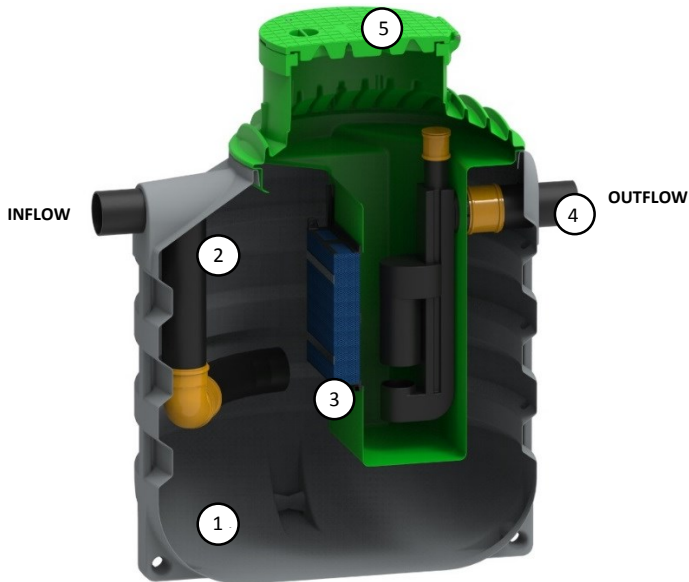

Water, previously cleaned with of sludge and other dirt, with the help of settler (1). After the appropriate level has been reached, water passes through the filter to the oil separator chamber. Here it assumes the function of further purification the coalescence filter (3). All the oil and grease impurities are removed in the coalescent filter. If there is a great amount of oil in the oil separator chamber, an automatic closure device installed on the outlet (4), prevents oil to flow out of the oil separator. Such purified water is then discharged from the oil separator through the drain into the watercourses. If coalescent filter (3) is not installed, the water is purified to the extent it can be released into the sewage system. Water from reservoir drains through outlet pipe (4) to the sewage systems. On the top there is opening (5) through which pollution of waste water can be controlled.



GENERAL PROPERTIES

Manufacturer: ROTO Eco d.o.o. Puconci 12, 9201 Puconci	Customer:
PRODUCT: ROTO OIL SEPARATOR	
Bill account number: _____	
Standards	EN 858-1:2002, EN 858-1:2002
Oil separator type	
Flow (L/s)	
Total volume (L)	
First chamber volume (L)	
Second chamber volume (L)	
Oil separator material	
Year of production	

OWNER AND LOCATION

OWNER:

Name / Surname	
Street Address	
Zip Code / City	
Country	
Mobile number	
E- mail	

LOCATION AND INSTALLATION:

Building	
Location	
The company that installed the separator	
Responsible person	
Date of installation	

2. USE OF OIL SEPARATOR

ROTO oil separators are in use everywhere where there is a possibility for mineral oils to reach rivers, streams, lakes, ponds, groundwater, soil, nature. Mineral oils are organic non polar compounds of carbon and hydrogen, the general formula is $C_nH_n + 2$ and the density is $\rho < 1 \text{ g/cm}^3$ (floats on the water), those are diesel, biodiesel, hydraulic oils, gearbox oils, machine oils, etc. Mineral oils are produced due to traffic, spillage, leakage of fuel tanks and other aggregates at places of external and internal cured areas, parking lots, garages, warehouses, etc..

ROTO oil separators are used in the treatment of waste water by the extraction of light liquids, They are designed in accordance with the standard SIST EN 858-1, SIST EN 858-2 and the waste water regulations 47/05.

Oil separators are divided into two classes. Class I with a flow rate of up to 5 mg/L are coalescent (with installed coalescent filter) and are used where meteor or waste water outflow into nature.

Oil separators with by-pass (10% or 20%) are designed for higher flow rates. At the major rainfall when the flow rates are high, 10% of the water goes through the oil separator and the other 90 % through the by-pass.

Size of the oil separators is determined by the nominal number (NS), which is equal to the flow rate L/s.

3. COMPONENTS OF OIL SEPARATOR

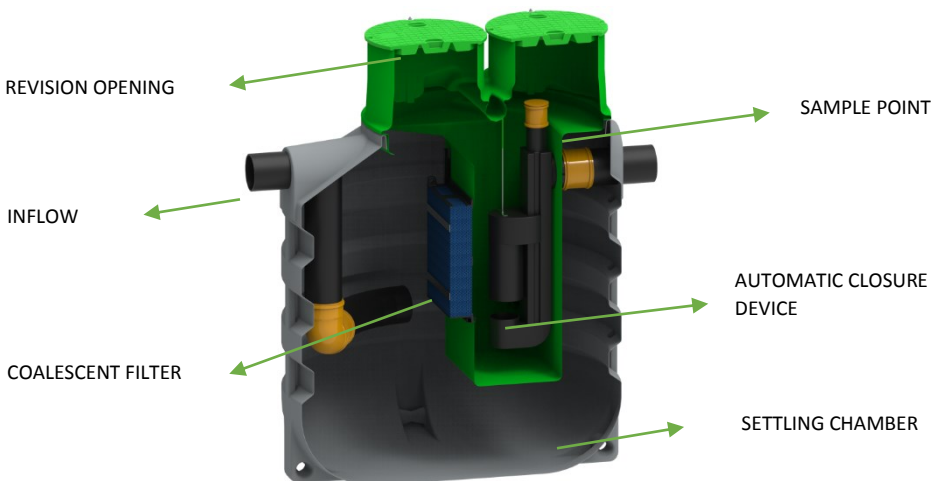

OIL SEPARATOR TANK

Reservoir, inlet knee (pipe), outlet knee (pipe), extensions and covers are made of naturally friendly polyethylene (PE), which can be 100 % recycled after use. Oil separator is intended for underground installatio and is accordingly dimensioned. It is made of one piece with rotomoulding technology, so it is 100 % watertight.

Oil separator has a built-in polyethylene separation chamber, into which the housing and the coalescence filter are installed.

Reservoir has a large entry opening (800 or 600 mm) with extension. The opening is intended to easy remove a coalescent filter when the oil separator is under maintenance (cleaning and unloading oil).

Each oil separator is exposed to internal control from production to delivery to the customer.



AUTOMATIC CLOSURE DEVICE

Automatic closure is made of polyethylene (PE). Depending on the customer's requirements, it can be installed on the inlet or outlet of the separator. Regularly the automatic closure device is installed on the outflow.

Automatic closure device is made of pipe and the float, which is floating on the water but not on the oil. If too much oil is accumulated in the separator, the oil moves the float down and prevents (block) the water to outflow through the pipe. When maintain the automatic closure device, oil separator must be emptied and refilled with clean water. Each automatic closure device is tested and calibrated in production.



COALESCENT FILTER

Type: Net separator

Unit dimensions: 300 x 300 x 8 mm

Coalescent filter consists of several lamellas and is inserted into the housing. The material is resistant to the aggressive effects of petroleum products.

Coalescent filter is located in the walls of a special housing. Bigger droplets of oil floats on the surface due to lower density of water. Small droplets are dispersed through the entire surface of the water and aggregate through the filter into a larger one. Larger droplets volume increases and thus the lift, so they rise to the surface. The droplet lift force is opposite to the weight of the gravity and is equal to the weight of the displaced liquid.

Instructions for maintenance and cleaning of the filter can be found under the maintance in section 4.

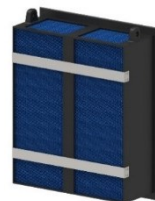

COVERS

In the case of walk-on surface, PE cover with diameter of 600 or 800 should be installed. This type of cover can be loaded up to maximum 200 kg.



In the case of installing oil separator under the traffic surface, cast iron cover must be installed.



4. MAINTENANCE

GENERAL

To ensure correct and long lasting operation of the oil separator, proper supervision and regular maintenance of all vital parts of the device are required. To maintain the oil separator, a responsible person must be identified and maintenance plan must be followed.

Regular and extraordinary maintenance and cleaning of oil separators must be carried out by authorized companies that have previously been informed and familiar with the operation and maintenance of oil separators.

Any work with an open flame is prohibited in the immediate vicinity or in the oil separator itself. Prior to any dangerous work on the device, it is necessary to pre-made safe work instructions in accordance with the applicable regulations and laws.

PLAN OF MAINTENANCE AND CONTROL

The control of the oil separators must be carried out in accordance with the maintenance and control plan and after every major rainfall.

PERIODIC CONTROL	ACTIVITY DESCRIPTION
Weekly control	- Check the level of the sludge in first chamber
Monthly control	- Check the level of the sludge in first chamber - Check the oil level
Half-yearly control of an authorized person in accordance with SIST EN 858 - 2	1. Settler: - Check the oil level and sludge 2. Separator - Check the oil level and sludge
5 year control of an authorized person in accordance with SIST EN 858 - 2	- A detailed overview of the oil catcher is required every 5 years. Oil separator needs to be emptied and cleaned entirely. Review must include: - Overview of all built in components (pipes, automatic closure, filters) - Visual inspection of the inside of the tank (possible cracks or deformations) - Automatic closure device inspection and test
Extraordinary control	- It is necessary to check operation of the automatic closure device after any major rainfall

DISPOSAL OF WASTE OIL

Waste oil, removed from the separator is prohibited from omitting into nature, water treatment plants, discharges, septic tanks, faecal sewage or watercourses. Captured waste oil must be collected and disposed off in accordance with the applicable legislation (rules for handling with special waste).

Amount of oil removed from oil separators must be controlled in accordance with the maintenance plan and the control through the inspection opening. When the RF spindle is in the red field, it is necessary to empty the oil from separator. Pumping oil can be done through the second opening, which allows access to both chamber of oil separator. When removing oil, care must be taken to remove as much oil as possible.

Therefore, it is necessary to perform the emission of the oil layer carefully and with suitable devices that are intended for this purpose.

MAINTANCE WORK INSIDE THE OIL SEPARATOR

Before each entry into the oil separator, it is necessary to remove oil and waste water from it. Before starting the work inside, the separator must be constantly ventilated. It is obligatory to use protective clothing and masks with appropriate filters for all works inside the separator. Work on the inside of the separator must be carried out by at least two workers. The worker inside must be in constant contact with the worker outside. The entrance to the oil separator must be carried out with tripod stand – the worker must be permanently attached to the guard rope that is connected to the stand. After completion of the work, separator must be filled with clean water. It is necessary to install covers after the maintenance to prevent flow of impurities into the chamber.

CLEANING

Individual parts of the oil separator can only be cleaned with cold cleaners (biodegradable disposable media), which have the appropriate certificates from authorized institutions in Slovenia. Coalescent filter in oil separator can be cleaned with high pressure cleaners. After cleaning, filters must be immediately inserted back into the casing and in the reservoir of the separator. Filters are not UV-stable and can lose their properties and become fragile at long exposure on the sun. When cleaning coalescent filter, sewages with hazardous waste are generated, therefore cleaning of the filters in a special place, which has a waste water collector is required.

MEASURING SEDIMENTS IN FIRST CHAMBER:

- When the water in the separator is completely calm, push the rod slowly to the bottom of the tank. Slowly take the rod out and read how many centimeters of the stick is from the cover out and write like $x = \dots$ cm,
- Mount circle on the stick and under the same conditions, drop the rod with a circle into the reservoir – oil separator, slowly descend to reach the surface – the upper surface of deposits. Read how many centimeters of the stick is above the cover and write it like $y = \dots$ cm,
- Deduce the y reading from x reading to obtain the sediment height.
- If the total height of the water is, for example 400 mm it is necessary to empty the reservoir.

ANALYSIS PROCEDURE IN A SECOND CHAMBER:

- Grease the measuring tape with the attached paste 10 cm higher than the level of the liquid. The measuring tape must be dry and the oil inside the tank must be calm.
- Slowly lower measuring tape to the bottom of the tank.
- When the measuring tape reaches the bottom, wait approx. 15 seconds to react, which shows the height of the oil.
- Slowly and carefully lift up the measuring tape from the tank and read the height of the oil.
- The area on measuring tape where the color is RED, indicates height of WATER.
- If the oil from the surface to the interior is colored with oil color, it is necessary to clean the oil separator. Cleaning may only be carried out by an authorized organization. We must pay attention to avoid closing of the guard in the filter, as there may be an ingress of water above the lid or into the building. Release the flow physically and order cleaning. In order to prevent this, it is necessary to carry out controls on the content of oils in the separators and to discharge continuously.

CLEANING THE FILTER

Clean the filter when the sludge and waste oil are drawn from the separator. The cleaning process takes the following steps:

- Remove the cover of the oil separator.
- Remove top oil layer from the oil separator.
- Filters are attached to the movable housing, which is easily withdrawn from the guides of the chamber wall from the oil separator. Metal closure on the housing must be released.
- Filter can be lifted from the separator through the inspection opening with lifting device. Care must be taken not to damage the casing or the inspection opening while lifting the filter. If there are several filters in the catcher, take them out of the chamber wall individually.
- Authorized person or authorized company cleans the filters and changes the labels if they are damaged.
- Clean the filters by pulling them out of the separator and clean it with high pressure water jet cleaner. Clean the filters on the areas where there is controlled collecting waste water.
- Insert filter with the housing through the large opening of the oil separator tank.
- Fix the filter housing back into the chamber wall with a metal closure.
- Close oil separator with a lid/cover.
- During maintenance with a high pressure water jet cleaner, clean the partition wall of the separator and inflow hose. After cleaning, tank must be filled with clean water.



CLEANING OF SENSORS, ALARMS AND OIL LEVEL MEASURES

When cleaning, additional electronic sensors, alarms and oil level measures must be wiped out with a soft cloth, taking care not to damage the sensors.

An automatic closure device can be serviced through an inspection opening on the oil catcher.

5. TRANSPORT AND INSTALLATION OF OIL SEPARATOR

MANIPULATION WITH OIL SEPARATORS

Oil separator can only be moved by lifting. It should not be moved by rolling or towing on the surface. When lifting oil separators, the joining strips are used. Use of chains or steel cables is prohibited. Oil separator should be placed on a clean and flat surface.

TRANSPORT

Oil separator must be held down on a smooth and straight surface during transportation. Please pay attention to any sharp edges which may cause damage on the tank. The tank should be attached with polyester straps or straps made of similar materials. Please make sure the straps are not too tight, causing deformation of the oil separator shell.

TEMPORARY STORAGE

Oil separators should be stored on an appropriate, smooth and straight surface. Please make sure that the surface is free of any sharp objects which could damage the tank of the oil separator. If any damage should occur on the tank prior to installation, the manufacturer should immediately be informed. Repairs should be made according to the manufacturer's written instructions.

BEFORE THE INSTALLATION

Soil composition and characteristics should be checked before the oil separator is installed. The bottom of the construction pit should be hardened/fortified and stable. In case of inadequate ground load capacity, a 40 cm thick layer made of gravel material or concrete should be made. Layer should be hardened to the compaction rate 60 MPa. The excavated material from the construction pit should be removed in order not to be mixed with the filling material. If any ground water is present, it needs to be completely pumped out.

DIMENSIONS OF THE CONSTRUCTION PIT

The useful size of the construction pit should be 60 - 100 cm larger than the useful size of the oil separator. Oil separator should be installed a minimum of 150 cm away from the building, and a minimum of 200 cm from traffic surfaces. If the characteristics of the terrain allow for it, the walls of the construction pit should be dug as vertically as possible ("safe" angle of excavation and work safety rules should be considered.). Valid work safety and construction related regulation must be respected. Depth of the excavation pit must be adjusted with projects and tank dimensions.

FILLING MATERIAL

Material used to fill the construction pit must be of proper granulation. Filling material should be clean, without ice or snow, without clay, particles of larger granulation and free of other organic particles. Oil separator should be backfilled with gravel of granulation 4-16 mm. Filling and compressing of gravel should be carried out in steps, i.e., in layers of thickness of 300 mm. During installation, the tank should be filled with water to the same level as the height of the filling material, so that both internal and external levels are the same. This allows equal side pressure to the wall of the tank.

ANCHORING THE OIL SEPARATOR

Anchor hooks (20 mm diameter steel reinforcement rod) must be installed into the foundation slab. A stainless steel rope (12 mm diameter) should be attached to the hooks with wire clamps. The rope should be tightened with a turnbuckle hook. All fastening materials should be made of stainless steel. To prevent direct pressure on the tank, geotextile (width approx. 100 mm) should be placed between the tank surface and the rope. Tanks with handling rings should be anchored to hooks on handling rings.

FOUNDATION SLAB

Reinforcement concrete foundation slab should be made on top of a fortified/hardened and firm surface. Reinforcement concrete foundation slab's minimum thickness must be 200 mm (dimensioning to be determined by a professional statics expert). The slab should be fortified with two steel reinforcement meshes. Foundation slab should be 600 mm wider than the tank's external width.

PIPELINE TO THE OIL SEPARATOR

For all oil separators it is possible to make inlet and outlet with conventional plastic pipes. On the oil separators there are tubular fittings to which plastic tube can be connected.

REINFORCEMENT RING (in the case of a traffic load)

Traffic load should not be directly transported over the tank. Therefore, an reinforcement concrete relief plate must be made around the entrance opening, through which the transport load is transmitted to the sink material. Reinforcement must be dimensioned by static, depending on the load. The recommended quality of the concrete ring is C 30/37.

PHOTO DOCUMENTATION

In order to claim the warranty in case of damage to the oil separator, the entire installation of the separator must be photo-documented. The manufacturer is not responsible for any damages to the separator if the technical file is not observed.

5.1. SIMPLE UNDERGROUND INSTALLATION

1. External sizes of the construction pit should be 60 - 100 cm larger than the tank's external length and width. If the characteristics of the terrain allow it, the walls of the construction pit should be dug as vertically as possible ("safe" angle of excavation should be considered and work safety rules respected.).
2. Construction pit planum layer should be straight, fortified and hard. If the soil has a lower bearing capacity, layer of a 40 cm thick layer of gravel material or concrete should be made. The layer should be fortified to the compaction rate of 60 MPa.
3. 15 cm thick sand bedding should be put on top of the prepared layer. The sand layer should be leveled out.
4. Carefully place the tank onto the sand bedding (placement with appropriate mobile crane or excavator) and level the sand out using a level measuring tool. Using the coil adjust the telescopic elevation to the final level of the terrain.
5. The construction pit is filled up with 4-16 mm gravel fraction to the tank height of 30 cm, measured from the bottom of the tank, while the tank is simultaneously being filled up with water up to the height of 30 cm measured from the bottom of the tank (make sure all chambers are filled). Please make sure that the curved parts of the tank are well filled with the fraction from all outer sides. Simultaneous filling of the pit with fraction and the tank with water should be made in 30 cm steps, until the pit is completely filled (25 cm below the level of the lid).
6. The inflow and the outflow are then connected to the tank.
7. Across the entire area of the tank, geotextile must be laid.
8. The top 25 cm are filled in with soil. Please make sure that the tank lid remains uncovered. Attach the tank lid to the tank neck with supplied screws.
9. Maximum height of gravel and soil above the tank is 70 cm.
10. If the surrounding terrain is impermeable, the drainage should be made around the tank.

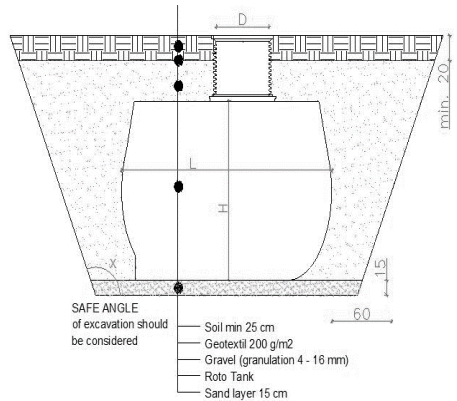

5.2. UNDERGROUND INSTALLATION WITH GROUND WATER

- External sizes of the construction pit should be 60 - 100 cm larger than the tank's external length and width. If the characteristics of the terrain allow it, the walls of the construction pit should be dug as vertically as possible ("safe" angle of excavation should be considered and work safety rules respected.).
- Construction pit planum layer should be straight and fortified and hard. If the soil has a lower bearing capacity, a layer of a 40 cm thick layer of gravel material or concrete should be made. Layer should be fortified to the compaction rate of 60 MPa.
- Approx. 20 cm thickness floor reinforced concrete slab should be made on top of the prepared surface. The floor slab must be 60 cm wider than the dimensions of the tank (the dimensioning of reinforced concrete floor slab should be made by a professional statics expert). Stainless anchors must be inserted into the floor slab.
- Carefully place the tank on the reinforced concrete slab (placement with appropriate mobile crane or excavator) and level it using a level measuring tool. Using the coil adjust the telescopic elevation to the final level of the terrain. Attach the tank to the built-in anchors with a braided steel rope 12 mm in diameter. All fastening materials should be stainless.
- The construction pit surrounding the tank should be filled in with minimum C 12/15 quality concrete to the maximum height of the underground water. Please make sure that the curved parts of the tank are well filled in from all outer sides. The tank (all chambers) should be simultaneously filled with water while the pit is being filled on the outside. Simultaneous filling of the pit with concrete and the tank with water should be made in 30 cm steps - until the maximum level of the underground water is reached. The space between the maximum level of the water and the 25 cm below the top of the tank should be filled with 4- 16 mm gravel fraction.
- The inflow and the outflow are then connected to the tank.
- The top 25 cm should be filled in with soil (200 g/m² geotextile should be laid prior to filling). Please make sure that the tank lid remains uncovered. Attach the tank lid to the tank neck with supplied screws.
- Maximum height of gravel and soil above the tank is 70 cm.
- If the surrounding terrain is impermeable, the drainage should be made around the tank.

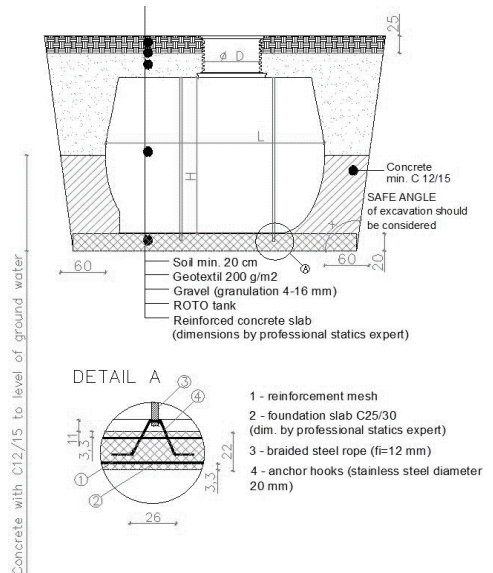

5.3. INSTALLATION BELOW TRAFFIC SURFACES

1. External sizes of the construction pit should be 60 - 100 cm larger than the tank's external length and width. If the characteristics of the terrain allow it, the walls of the construction pit should be dug as vertically as possible ("safe" angle of excavation should be considered and work safety rules respected.).
2. Construction pit planum layer should be straight, fortified and hard. If the soil has a lower bearing capacity, a layer of a 40 cm thick layer of gravel material or concrete should be made. Layer should be fortified to the compaction rate of 60 MPa.
3. 15 cm thick sand bedding should be put on top of the prepared layer. The sand layer should be leveled out.
4. Carefully place the tank onto the sand bedding (placement with appropriate mobile crane or bagger) and even the sand out using a level measuring tool. Telescopic elevation is adjusted to the desired level with the extension coil.
5. The construction pit is then filled up with 4-16 mm gravel fraction to the tank height of 30 cm, measured from the bottom of the tank, while the tank is simultaneously being filled up with water up to the height of 30 cm measured from the bottom of the tank (make sure all chambers are filled). Please make sure that the curved parts of the tank are well filled with the fraction from all outer sides. Simultaneous filling of the pit with fraction and the tank with water should be made in 30 cm steps, until the pit is completely filled (25 cm below the level of the lid).
6. The inflow and the outflow are then connected to the tank
7. Across the entire area of the tank, geotextile 200 g/m² must be laid.
8. Reinforcement concrete slab to relieve the pressure of approx. 20 cm thickness should be made on top of the geotextile (dimensioning should be made by a statistics expert according to load).
10. Cast iron lid should be mounted onto the tank inlet.
11. Maximum height of the mound above the tank is 70 cm.
12. If the surrounding terrain is impermeable, the drainage should be made around the tank.

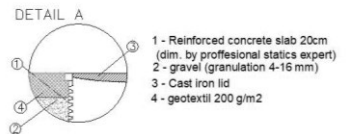
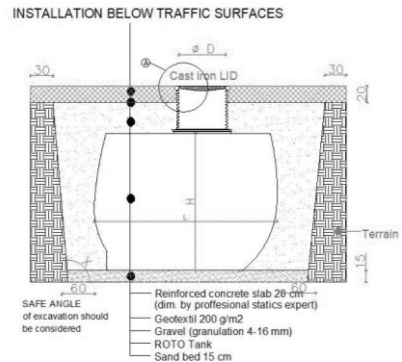

5.4. INSTALLATION DEEP BELOW THE GROUND

1. External sizes of the construction pit should be 60 - 100 cm larger than the tank's external length and width. If the characteristics of the terrain allow it, the walls of the construction pit should be dug as vertically as possible ("safe" angle of excavation should be considered and work safety rules respected.).
2. Construction pit planum layer should be straight, fortified and hard. If the soil has a lower bearing capacity, a repair layer of a 40 cm thick layer of gravel material or concrete should be made. The repair layer should be fortified to the compaction rate of 60 MPa.
3. 15 cm thick sand bedding should be put on top of the prepared layer. The sand layer should be leveled out.
4. Carefully place the tank onto the sand bedding (placement with appropriate mobile crane or bagger) and even the sand out using a level measuring tool. Telescopic elevation is adjusted to the desired level with the coil.
5. The pit is then filled up with 4-16 mm gravel fraction to the tank height of 30 cm, measured from the bottom of the tank, while the tank is simultaneously being filled up with water up to the height of 30 cm measured from the bottom of the tank (make sure all chambers are filled). Please make sure that the curved parts of the tank are well filled with the fraction from all outer sides. Simultaneous filling of the pit with fraction and the tank with water should be made in 30 cm steps, until the pit is completely filled (25 cm below the level of the lid).
6. Connect the inflow to the tank, and the outflow to the underground water or extend it to surface water or a pit.
7. 200 g/m² geotextile is placed on top of the filled area²
8. Reinforcement concrete slab to relieve the pressure of approx. 20 cm thickness should be made on top of the geotextile (dimensioning should be made by a statistics expert according to load).
9. Access Polyethylene (PE) shaft with a minimum of a 100 cm opening should be placed on top of the pressure-relief reinforcement concrete slab. Depth of the pit should be adjusted to the final terrain level. Access stairs must be made for greater depths.
10. Access pit surface should be covered with concrete.
11. Polyethylene (PE) or cast iron cover should be mounted on top of the access pit.
12. If the surrounding terrain is impermeable, the drainage should be made around the tank.

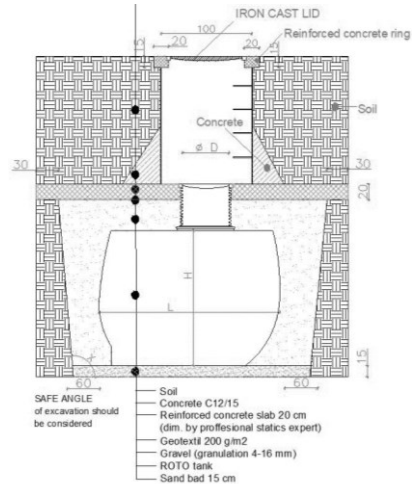

6. WARRANTY

The product will operate within the warranty period if the user follows the attached instructions for installation, use and maintenance of the oil separator.

The manufacturer shall provide the consumer with spare parts for at least 36 months after the expiration of the warranty period

Warranty period:

- 60 months of the watertightness of the tank
- 24 months for the operation of electronic parts if installed.

The warranty period begins on the day of the purchase. The date of purchase is stated on the invoice, which is necessary for claiming a guarantee upon reclamation.

The warranty expires:

- non-compliance with the instructions provided or negligent handling of the product
- improper use of the product,
- mechanical damage through the fault of the user or a third person,
- unauthorized person tampering with a product,
- when adding or using non-separated elements,
- improper maintenance behavior
- accidental injury – flood, fire, earthquake or other higher force

The customer can only claim the rights under the warranty if he informs the seller within the warranty period.

Warranty conditions:

- purchase of the oil separator should be appropriately sized (amount of waste water, number of households).
- municipal water supply in accordance with the parameters specified in the technical file,
- Installation according to the manufacturer's instructions
- Proper maintenance of the separator
- The obligatory attachment for claiming the warranty is the photo documentation of the installation

The warranty and reclamation procedure is only performed within the framework of the ROTO reclamation procedures.

We recommend service by an authorized ROTO servicer at least once in 24 months.

Technical service:

Tel.: 02/ 5252 196 or Email: servis@roto.si

7. ATTACHMENTS

7.1. MAINTENANCE



Secure the space around the opening at the time of emptying



Carefully open cover of the oil separator



Pull out the sludge



Pull out oil



Check the components inside the oil separator and clean them if necessary



Carefully close cover of the oil separator



7.4. RULES OF PROCEDURE

(COMPLETE BUYER)

1.

These rules govern the discharge and maintenance of the oil separator, manufactured by ROTO.

The product is located next to the _____;

is the content of _____ and is intended only for effluents from _____.

2.

The sewage flows from the parking in or near the facility, through the sewage system in the oil separator. Oil separator should be emptied as needed or 1x annually. An authorized cleaning company for oil separators must ensure regular maintenance according to the standards and rules of local laws. The oil must be exhausted and removed for further processing operations.

During maintenance, oil separator walls must be cleaned by the inlet and outlet hose with the high pressure cleaner. The lid and the lifting tube must be visually inspected. Coalescent filters installed in the oil separator must be removed and washed with a high pressure cleaner. After the cleaning process, oil separator must be filled with clean water in accordance with ensuring proper operation.

3.

A contract for the removal of waste oil with an appropriate company selected by the owner of oil separator is required. Rain and fecal water or any other water that does not come from parking lots should not be taken into the oil separator. Oil separator is not intended for starch and fatty waste.

4.

For the purpose of implementing these rules of procedure, a cleaning log is kept. The operation diary shall show data on the date of control, cleaning or washing and any special findings.

5.

An authorized person for the implementation of these Rules is: _____.

Rules are valid from _____ on.

Buyer signature:



Puconci 12 | Murska Sobota | Slovenia

Tel.: + 386 (0)2 52 52 152

Faks.: + 386 (0) 52 52 161

eco@roto.si | servis@roto.si

www.rotoECO.eu

All rights reserved, including the rights of photomechanical reproductions and storage on electronic media. The manufacturer reserves the rights to change the product. Any commercial use of the processes and working procedures assumed in this document is prohibited. Although information, texts and photos were carefully collected. The mistakes can not be completely excluded. The publisher and editors can not assume legal responsibility or guarantee any incorrect information. The publisher and editors are grateful for any possible suggestions for improvements and warnings of possible mistakes in the text.